

TECHNICAL CATALOGUE



DRIVES
drivon[®]

STANDARD **IEC**



MOTOVARIO[®]
HEART OF MOTION
a **TECO** Group company

1. GENERAL INFORMATION

1.1	COMPANY PROFILE	3
1.2	PRODUCTS AND SOFTWARE MOTOVARIO	5

2. SYMBOLS

2.1	SYMBOLS	9
-----	---------------	---

3. INTRODUCTION

3.1	INTRODUCTION	10
3.2	INDUSTRY SECTORS	11
3.3	INVERTER CHARACTERISTICS	12

4. PLUS & BENEFIT

4.1	PLUS & BENEFIT	13
-----	----------------------	----

5. DESIGNATION

5.1	DESIGNATION	14
-----	-------------------	----

6. DIRECTIVES AND STANDARDS

6.1	DIRECTIVES AND STANDARDS	15
-----	--------------------------------	----

7. OPERATING CHARACTERISTICS

7.1	OPERATING CHARACTERISTICS	16
-----	---------------------------------	----

8. VERSIONS

8.1	VERSIONS	17
8.2	VERSION DV123	18

8.3	VERSION DV340	19
-----	---------------------	----

9. TECHNICAL DATA

9.1	RANGE	21
9.2	PERFORMANCES	22
9.2.1	Version DV123	22
9.2.2	Version DV340	24
9.3	DIMENSIONS	28
9.3.1	Mounting positions B5	28
9.3.2	Mounting positions B14	29
9.3.3	Mounting positions B3	30
9.4	WEIGHTS	31

10. ACCESSORIES AND OPTIONS

10.1	ACCESSORIES AND OPTIONS	32
------	-------------------------------	----

11. SALES CONDITIONS

11.1	SALES CONDITIONS	35
------	------------------------	----

Motovario® corporate philosophy aims to promote the company's brand and products at an international level with determination and transparency, while constantly striving to offer innovative solutions for satisfying and anticipating the demand of the market. Motovario® provides technologically advanced solutions in the transmission components field for industrial and civil applications worldwide.

The company

At Formigine, the heart of Modena's industrial district, Motovario® boasts a production plant spanning 50,000 m² that employs 500 people.

1965 Foundation of Motovario

1998 Acquisition of Spaggiari Trasmissioni, an important brand in the mechanical technology sector.

2006 Motovario acquisition by a private investment fund managed by Synergo SGR, in order to guarantee its development and support its expansion throughout the world.

2014 Acquisition of Pujol.

2015 Acquisition by TECO.

At the core of Motovario® lies an evolved production process based on technological solutions that convert power into movement. Motovario® is at the heart of the production processes that drive industries worldwide. Quality and reliability are the company's fundamental assets. Motovario® is present throughout the world with branches in France, Spain, Germany, England, China, the United States and India. The sales network and customer service guarantee immediate and high-quality support to all customers. In addition, the company boasts a worldwide network of MAC (Motovario Assembly Centre). Qualified assembly centres are present, in Italy, Australia, Benelux, Bulgaria, China, Finland, France, India, Ireland, Israel, Malaysia, Poland, Portugal, South Korea, Spain, Sweden, Turkey, United Kingdom, Ukraine and USA. The company is able to offer a wide range of products: speed variators, right-angle, helical-bevel, shaft-mounted, worm gear reducers and gearmotors, electric motors, inverter and inverter drives. Maximum quality and precision are ensured by the cutting-edge technologies implemented in the production process. 170 numerical control machines, served by LGV lines for storage in automatic warehouses, ensure a high standard of efficiency for the Motovario® production department.

The highly automated assembly lines are supported by a specific computerised system. The process statistical control system manages the production process to avoid rejects, by enabling the operator to monitor all the processing phases. The annealing, tempering, hardening and carburizing treatments are carried out inside the plant. The plant operates on a 24-hour basis, including holidays. Reliability, resilience and versatility are the distinctive features of Motovario® products, the most qualified solution to any power transmission requirement.

Main fields OF APPLICATIONS

- Mechanical-electromechanical industry (car washing, pumps, barriers & automatic doors, circuit breakers)
- Ceramic industry (ovens, press feeding systems)
- Food, farming, oenology industry
- Wood, marble, glass industry
- Packaging & bottling industry
- Textile, shoes, leather industry
- Transport, logistic industry
- Construction industry
- Milling, animal husbandry, flower industry
- Machine tools & steel industry
- Mining, quarry, cement industry
- Energy industry (solar, nuclear, biomass, wind)
- Amusement industry (theatres, leisure parks, kiddy rides)
- Chemical & pharmaceuticals industry
- Paper & printing industry
- Plastic & rubber industry
- Telecommunications industry (satellite orientation systems, military radar)
- Engineering and consultant companies

Certifications

Our products can be manufactured to conform with the ATEX Directive 2014/34/UE. In addition, the safety and quality of our motors, geared motors and motovariators is guaranteed by the EAC (EurAsian Conformity) certification, an essential requirement for products exported to the Russian Federation. Our motors are UL certified, which guarantees their safety and quality requirements for the North American market.

Quality CONCEPT

Motovario® has obtained the quality certification renewal of its production system in conformity to the UNI EN ISO 9001:2008 standard. This internationally recognised certification acknowledges the company's commitment and drive geared towards constantly improving products, projects and services offered. Moreover, the company has obtained the OHSAS 18001:1999 (Occupational Health and Safety Assessment Series) certification, which defines the requirements of the workplace safety and health management system.

Research & DEVELOPMENT

Technological innovation: a crucial factor for competing in the market. In the company's 50-year history, research and change have been the pivotal factors in guaranteeing competitiveness at a global level, thanks to increasingly advanced products in terms of performance and reliability. Each year the company invests an increasing amount of its turnover in research and development, geared towards promoting the constant study and analysis of products, control processes and performance certification. In order to ensure that customers receive products that comply with the requested performance levels, the company carries out simulations on all new products, including NVH (Noise, Vibration, Harshness) tests effected in the advanced semi-anechoic chamber.

Customer CARE

Innovative instruments and software applications supporting the technical and logistic requirements of our partners worldwide guarantee a timely and customised service. The experience acquired by Motovario® has led to the creation of the new online portal MyMotovario 4.0, which allows for selecting products and exporting their 3D file. As a result, designers and engineering departments can download the three-dimensional model of the requested product and implement it directly in their own layout. In order to maximise customer service and quality, Motovario® offers all its customers the following online services: Order Tracking, which allows for monitoring the progress of an order in real time, and the Stock Availability service, through which users may check the availability (stock) of our products, both in the Italian plant and in the various branches.

Motovario chooses technological evolution.

Motovario® has chosen technological evolution and actively collaborates with the Faculty of Engineering of the University of Modena and Reggio Emilia and of the University of Bologna.

Reliability, sturdiness, versatility

These are the distinctive traits of Motovario products. A broad range of transmission products that provide a competent, innovative solution to each and every power application need. Cutting-edge tools, unrelenting research efforts and ongoing commitment to upgrading manufacturing equipment to the latest state-of-the-art enable us to offer high quality and performance standards to cater to industry requirements and the broadest variety of applications. Motovario ranks among the leading, well-reputed companies in Italy engaged in the design, manufacture and sales of transmission products for industrial and civil applications. The entire manufacturing process takes place in Formigine and Ubersetto plants, in Modena area, with an overall surface area of over 50.000 sq m. and a workforce of about 500 people. 170 numerically controlled machines and cutting-edge handling, storage and assembly automated systems ensure that all products meet high quality standards. The network includes more than 40 Motovario-certified assembly centres, with the capability to supply products in a broad range of versions, including customised versions, high service capacity and fast response. As a result, our product offering can cater to the needs of all plant engineering sectors, in all industries and for different applications, and includes: speed variators, helical, bevel-helical, parallel helical, worm gear reducers and gearmotors, electric motors and motor-inverters. All of the products we manufacture share such common features as reliability, sturdiness and versatility, topped with a high innovation content. At the heart of a company's technological innovation is the ability to develop integrated tools for computer-aided calculation simulation and management of different processes as part of product development. When simulating operating, setup and process conditions, it is also necessary to analyse and optimize the overall functional design of a product using a synergistic approach. This is achieved by implementing an exhaustive experimental plan, without using interpolation or approximation, as they frequently allow criticalities or any oversizing which is not conducive to maximising quality/cost ratio to go unnoticed.

High-efficiency method for calculation according to standards

A set of specific functions have been developed to this end. A few significant examples include functions to:

- Optimise individual reduction ratios and the combinations of the different reduction stages based on parametrisable target normal series;
- Calculate torque values and maximum permissible external forces for gear reducer units, using iterative numeric algorithms to confirm target life/safety values of components;
- Create databases for loading a FEM structural analysis model by automatically writing all reaction components of bearings under all load conditions to a specific file, with automatic selection of critical cases that need to be verified.

Another goal of the method is to create synergy between calculation according to standards and FEM structural calculation and the implementation of FEM model loading procedures, so as to simplify input data, meshing and constraint criteria

Competitiveness and operational benefits of the new method

This method offers many practical advantages over traditional calculation procedures within the company, namely:

- Iterative optimisation of project since setup stage;
- Accurate assessment of the various service factors and reliability levels for the entire gear reducer unit and for all operating conditions as per catalogue rating or customer specific requirements;
- Faster support to customers in analysing tailored product configurations;
- Integrated corporate databases that can be updated in real-time;

Range extension and ongoing evolution

The steady, significant growth of Motovario Group is achieved thanks to an ongoing search for new calculation and design tools, as well as to customer service. The new tools identified have led to innovation, improved product reliability as well as positive developments in market management. The following software products are used for design, calculation and management:

- Solidworks;
- Kisoft;
- Kissys;
- Ansys;
- FEM modelling analysis software;
- Circuit design and simulation software;
- Specific spreadsheets;
- SAP.

In MyMotovario 4.0 portal, PRODUCT SELECTION includes a section named APPLICATIONS where customers can enter application data and find out which gear reducer suits them best in a matter of minutes.

MOTOVARIO Products

HELICAL GEAR REDUCERS

Cast iron or aluminum casing
 Output shaft up to 90 mm
 Mn₂ up to 8.600 Nm
 Reduction stages 1, 2, 3
 Ratios up to 354
 Atex units

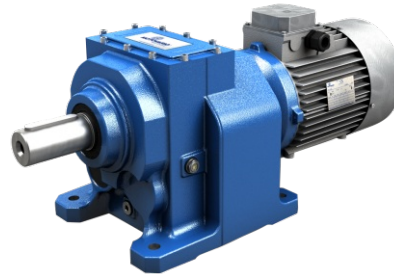
**HELICAL BEVEL GEAR REDUCERS**

Cast iron or aluminum casing
 Output shaft up to 110 mm
 Mn₂ up to 14.000 Nm
 Reduction stages 2, 3
 Ratios up to 443
 Atex units

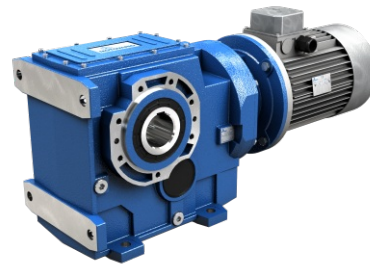
**SHAFT MOUNTED GEAR REDUCERS**

Cast iron
 Output shaft up to 90 mm
 Mn₂ up to 10.250 Nm
 Reduction stages 2, 3
 Ratios up to 395
 Atex units

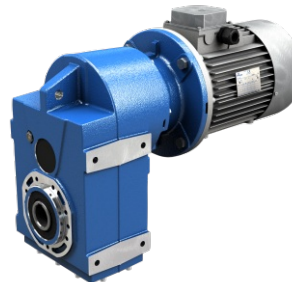
**WORM GEAR REDUCERS**

Cast iron or aluminum casing
 Output shaft up to 50 mm
 Mn₂ up to 2.700 Nm
 Ratios up to 1083
 Atex units



**PARALLEL HELICAL AND
BEVEL HELICAL GEAR REDUCERS
FOR MIDDLE HEAVY INDUSTRY**

Cast iron casing
Output shaft up to 180 mm
Mn₂ up to 110.000 Nm
Reduction stages 1, 2, 3, 4
Ratios up to 636
Atex units

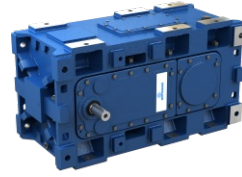
**MOTOVARIATORS AND
MOTOVARIATOR-GEAR REDUCERS**

Cast iron or aluminum casing
Ratios infinite
Mn₂ up to 5.000 Nm
Atex units



ELECTRIC MOTORS

Power ratings up to 90 kW
Poles 2, 4, 6
Three-phase and single-phase, built-in brake, dual polarity
Protection class up to IP66

**DRIVES****DRIVON - motoinverter**

Three phase and single phase power supply
High dynamics sensorless vectorial control
Power ratings up to 5,5 kW
Standard integrated STO
Integrated field bus
Optional field bus



2.1 SYMBOLS

P	Power (kW)
V	Voltage (V)
f	Frequency (Hz)
I	Current (A)
M	Torque (Nm)
n	Speed (rpm)
max	Maximum
min	Minimum
nom	Nominal

Drivon, designed to be used in different types of applications (especially pumps, fans and conveyor belts) consists of extremely reliable components and is controlled by our software that provides excellent performance with special attention to the system energy efficiency. Its Vectorial Control, besides ensuring a constant motor torque throughout a wide range of frequencies without requiring the use of the servo-ventilation at low rpm, provides fast and precise output according to the application dynamic conditions allowing high torque overload of the motor.

Conceived for extremely different and variable supply conditions, Drivon is available both in single-phase/three-phase version (200 ÷ 260 V / 47 ÷ 63 Hz) with a motor power between 0.25 and 1.5 kW, and in three-phase version (360 ÷ 480 V / 47 ÷ 63 Hz) with a motor power between 0.25 and 5.5 kW. The different functions of this software provide a wide range of standard and optional interfaces for a simple and flexible use. The electronic part, available in 10 power sizes, is located in two different chassis sizes, one for power up to 1.5 kW and the other for power up to 5.5 kW.

The product design considers the following aspects:

- power efficiency;
- modular configuration and expansion possibility;
- potential target markets;
- user-friendly;
- future design development flexibility.

Following these guidelines, Motovario has developed DRIVON, which belongs to the STANDARD segment along with all products of the reference competitors in the AC Induction market.

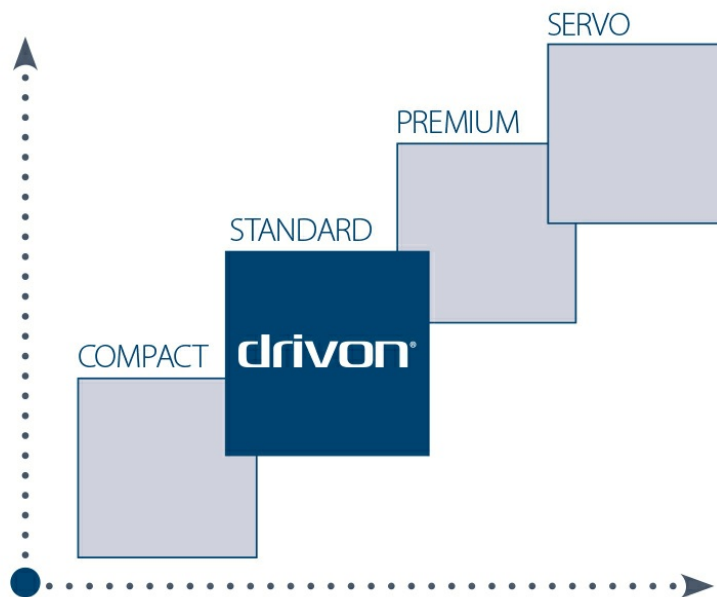

The features of DRIVON enable its application in many industry sectors that require specific performance and functions:

- CONVEYOR BELTS
- PALLETISERS
- PUMPS
- FANS
- SCREW CONVEYORS
- MIXERS
- ROTARY TABLES
- PRESSES
- WINDERS/UNWINDERS
- ELEVATORS (NO ZERO-SPEED)

3.3 INVERTER CHARACTERISTICS

- FOC open-loop control of asynchronous motors
- Input for incremental encoder as speed feedback
- Available according to UL/CSA standards
- Possibility to set parameters through field Bus
- Many functions may be assigned to digital inputs, in particular UP/DOWN function
- Possibility to set the reference frequency

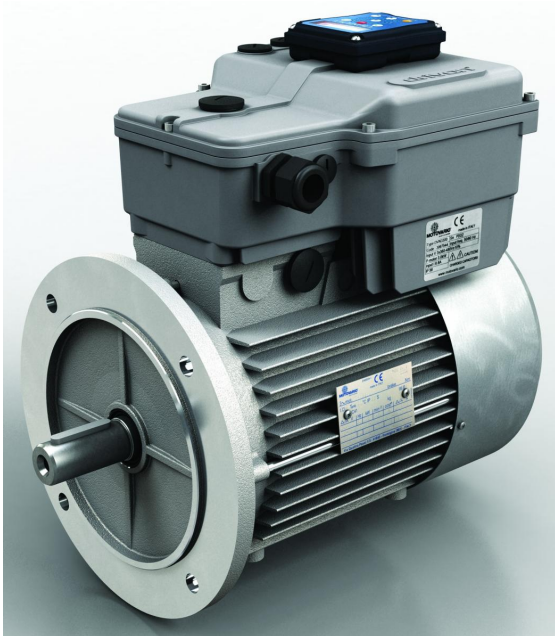

Motovario Drivon inverter motor is the solution to a series of applications present in many industrial environments. Conveyor belts, pumps, fans and other applications in which the decentralised solution is used for reducing the complexity and the overall dimensions of the switchboard and for reaching the performance and efficiency levels required by the market.

REDUCING THE USE OF FORCED-VENTILATION

The perfect integration between Motovario motors and the management software installed inside the Drivon allows to reduce the use of forced-ventilation in the applications that require low rpm. This is due to the optimisation of the software that integrates the motors' characteristics, but also the use of electric motors with IE2 power efficiency levels.

SMART KEYPAD



Thanks to the optional keypad and the parameter copy function, the use of Drivon is more practical and quick during the product set-up phase. This function enables to apply the same parameters to inverter motors with the same configuration. In addition it is possible to start the inverter motor in two directions and display several details on the keypad.

FIRMWARE UPDATE

The firmware update takes place through USB port, accessible by removing a cover located on the inverter case, and a software on PC.

PC SOFTWARE CONFIGURATION

The program grants access to all the inverter parameters for both reading and writing (on-line modification of the inverter parameters) and the relating save operation in a file on the PC. The configuration software also incorporates a digital oscilloscope for tracking the check values.

SAFE TORQUE OFF BUILT-IN SAFETY

The machine directive defines the safety requirements that each machine must comply with in order to be granted the CE marking and enter the market or be manufactured in the European Union countries. In order to do this, all machine operations must have a certain level of safety and be equipped with systems capable of being activated in the event of an emergency, so as to stop the motor and cut off the power supply, until the correct level of safety and the normal operating conditions are restored. To satisfy this safety need, Motovario has integrated in Drivon a Safe Torque Off system that cuts off the motor in case of an emergency, in compliance with ISO 13849-1.

5.1 DESIGNATION

Inverter Type	Power supply	Rated Speed (RPM)	Motor Inverter Power	Manual Adjustment Control	Accessories / Expansion Modules	Motor Type	Motor size	Motor Version	Brake Type	Brake Power Supply	Brake Control	Other Options
---------------	--------------	-------------------	----------------------	---------------------------	---------------------------------	------------	------------	---------------	------------	--------------------	---------------	---------------

DV	340	G3	0220M	KP1	IOA5	TBH	100L	B5	FM	/S	EMB6	UL
DV	123	G1	0025S	ISI	NO	TS	71A	B5	FM	/S	EMB5	IC416
	340	G2	0037S	KP1	IOA5	TH	...	B14	MS		EMB6	UL
		G3	0043S	KP2	IOB5	TBS	132MB	B3			BC	
		G4	0055S	KP3	PDP5	TBH		B35				
			0064S	KP4	ETC5			B34				
			0075S	PS5	IOA6							
			0095S	PS6	IOB6							
			0110S		PDP6							
			0130S		ETC6							
			0150S									
			0190M									
			0220M									
			0260M									
			0300M									
			0380M									
			0400M									
			0520M									
			0550M									

1/3PH 230V 123
3PH 400V 340

950 rpm G1
1450 rpm G2
1650 rpm G3
2450 rpm G4

025S 0.25kW inverter Small size
037S 0.37kW inverter Small size
....
190M 1.90kW inverter Medium size
220M 2.2kW inverter Medium size
....

EMB5 Electro Mechanical Braking Module in position 5
EMB6 Electro Mechanical Braking Module in position 6
BC Braking Chopper Module (sole position on the cover)

NO No Expansion Module
IOA5 I/O Module Type A in position 5
IOB5 I/O Module Type B in position 5
PDP5 Profibus DP Module in position 5
ETC5 Profibus Ethercat in position 5
IOA6 I/O Module Type A in position 6
IOB6 I/O Module Type B in position 6
PDP6 Profibus DP Module in position 6
ETC6 Profibus Ethercat in position 6

ISI Integrated Standard Interface
KP1 Keypad Pos.1
KP2 Keypad Pos.2
KP3 Keypad Pos.3
KP4 Keypad Pos.4
PS5 PotiSwitch Pos.5
PS6 PotiSwitch Pos.6

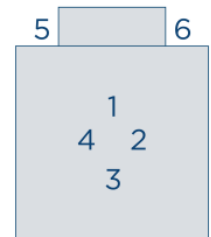

EN 61800-1:1998-02	Adjustable speed electrical power drive systems Part 1: General requirements and rating specifications for variable-speed low-voltage drives with d.c. motors
EN 61800-2:1998-04	Adjustable speed electrical power drive systems Part 2: General requirements and rating specifications for low-voltage drives with a.c. motors
EN 61800-3:2004-12	Adjustable speed electrical power drive systems Part 3: EMC requirements and specific test methods
EN 61800-5-1:2007-09	Adjustable speed electrical power drive systems Part 5-1: Safety requirements - Electrical, thermal and energy safety
EN 61800-5-2:2007-10	Adjustable speed electrical power drive systems Part 5-2: Safety requirements - Functional safety
EN 61800-7-1:2008-04	Adjustable speed electrical power drive systems Part 7-1: Generic interface and use of profiles for power drive systems - Interface definition
2014/35/UE	Low voltage directive
2014/30/UE	EMC directive (Electromagnetic compatibility)

AVAILABLE CERTIFICATIONS

UL (508c) „UL Standard for Safety for Power conversion equipment”

cUL (CSA C22.2 Nr. 14) „Industrial Control Equipment”

CE

Drivon is an inverter motor with sensorless field orientation speed control that also integrates a V/f control. Drivon is optimised for working at best with the Motovario motors, since the parameters of the motors are integrated in the inverter management software.

Drivon is capable of managing the speed variation, taking advantage of various sources that interact with the inverter motor by means of the built-in or optional I/O. Drivon can receive digital signals that, if properly programmed, can perform various functions, but it can also be controlled thanks to the integrated field bus (Modbus or CANopen) or by means of the optional ones.

Speed variation mode:

- Built-in potentiometer
- Keypad up/down buttons
- Up/down inputs from digital inputs (potentiometer motor)
- Fixed frequency selected from digital input binary combination
- Analogue input (programmable +/-10V or 0-20mA)
- Built-in potentiometer + analogue input algebraic addition
- 0-300KHz frequency input (on optional board)
- Modbus RTU register
- CANopen DSP402

With the programmable digital inputs it is possible to assign different functions to them, among which:

- start/stop
- motion inversion (relative direction control)
- clockwise start (absolute direction control)
- counter-clockwise start (absolute direction control)
- potentiometer motor
- fixed frequency binary combination
- quick emergency stop enable, according to a ramp that may be parametrised
- emergency stop enable at maximum current
- alarm

Drivon can also use the encoder for speed loop feedback through a special connector.

The optional keypad with integrated display provides several details, for example:

- Motor speed (rpm)
- Torque delivered (%)
- Torque current (A)
- Magnetic current (A)
- Reference frequency (Hz)
- Output frequency (Hz)

It is also possible to introduce a scale factor between the measure chosen from the previous list and the one actually displayed on the keypad.

FIELD BUS

Drivon is designed to be used in those applications that need to communicate with the automation world and this is why Motovario designed it with the possibility of relying on the Modbus RTU and CANopen DSP 402 communication protocols. These two field buses are integrated in the software and have special connections.

8.1 VERSIONS

The DRIVON model is available in two different versions, which are distinguished by

- Power supply type
- Power range
- Rated operating speeds

Version	Power supply	Power range	Rated operating speeds
DV123	1ph 230V	0.25 - 1.5 kW	950 rpm
			1450 rpm
DV340	3ph 400V	0.25 - 5.5 kW	950 rpm
			1450 rpm
			1650 rpm
			2450 rpm

The term rated operating speed can be understood as the minimum speed at which the motor-inverter delivers its nominal power with continuity, or rather the maximum speed at which it is able to guarantee its nominal torque with continuity.

In this version, the rated operating speeds G1 and G2 are only available at the power ratings of 0.25 - 1.5 kW.

RATED OPERATING SPEED G1:

Drivon	Supply voltage (ph x V)	Supply current at 230V (A)	Rated output (kW)	Rated operating speed (rpm)	Inverter size	Motor size
DV123-G1-0025S-TS71	1 x 180...260	1.1	0.25	950	S	71
DV123-G1-0037S-TS80	1 x 180...260	1.8	0.37	950	S	80
DV123-G1-0055S-TS80	1 x 180...260	2.5	0.55	950	S	80
DV123-G1-0075S-TH90	1 x 180...260	3	0.75	950	S	90
DV123-G1-0110S-TH100	1 x 180...260	3,9	1.1	950	S	100
DV123-G1-0150S-TH100	1 x 180...260	5,2	1.5	950	S	100

RATED OPERATING SPEED G2:

Drivon	Supply voltage (ph x V)	Supply current at 230V (A)	Rated output (kW)	Rated operating speed (rpm)	Inverter size	Motor size
DV123-G2-0025S-TS71	1 x 180...260	1,1	0.25	1450	S	71
DV123-G2-0037S-TS71	1 x 180...260	1,5	0.37	1450	S	71
DV123-G2-0055S-TS80	1 x 180...260	2	0.55	1450	S	80
DV123-G2-0075S-TH80	1 x 180...260	2,5	0.75	1450	S	80
DV123-G2-0110S-TH90	1 x 180...260	3,5	1.1	1450	S	90
DV123-G2-0150S-TH90	1 x 180...260	4,8	1.5	1450	S	90

This version is available with the rated operating speeds G1, G2, G3 and G4:

RATED OPERATING SPEED G1:

Drivon	Supply voltage (ph x V)	Supply current at 400V (A)	Rated output (kW)	Rated operating speed (rpm)	Inverter size	Motor size
DV340-G1-0025S-TS71	3 x 320...520	0,7	0.25	950	S	71
DV340-G1-0037S-TS80	3 x 320...520	1,2	0.37	950	S	80
DV340-G1-0055S-TS80	3 x 320...520	1,6	0.55	950	S	80
DV340-G1-0075S-TH90S	3 x 320...520	2	0.75	950	S	90
DV340-G1-0110S-TH100	3 x 320...520	2,5	1.1	950	S	100
DV340-G1-0150S-TH100	3 x 320...520	3,4	1.5	950	S	100
DV340-G1-0220M-TH112	3 x 320...520	4,7	2.2	950	M	112
DV340-G1-0300M-TH132	3 x 320...520	6	3.0	950	M	132
DV340-G1-0400M-TH132	3 x 320...520	8	4.0	950	M	132
DV340-G1-0550M-TH132	3 x 320...520	11	5.5	950	M	132

RATED OPERATING SPEED G2:

Drivon	Supply voltage (ph x V)	Supply current at 400V (A)	Rated output (kW)	Rated operating speed (rpm)	Inverter size	Motor size
DV340-G2-0025S-TS71	3 x 320...520	0,7	0.25	1450	S	71
DV340-G2-0037S-TS71	3 x 320...520	1	0.37	1450	S	71
DV340-G2-0055S-TS80	3 x 320...520	1,3	0.55	1450	S	80
DV340-G2-0075S-TH80	3 x 320...520	1,6	0.75	1450	S	80
DV340-G2-0110S-TH90S	3 x 320...520	2,3	1.1	1450	S	90
DV340-G2-0150S-TH90L	3 x 320...520	3,2	1.5	1450	S	90
DV340-G2-0220M-TH100	3 x 320...520	4,5	2.2	1450	M	100
DV340-G2-0300M-TH100	3 x 320...520	6,1	3.0	1450	M	100
DV340-G2-0400M-TH112	3 x 320...520	7,7	4.0	1450	M	112
DV340-G2-0550M-TH132	3 x 320...520	10	5.5	1450	M	132

RATED OPERATING SPEED G3:

Drivon	Supply voltage (ph x V)	Supply current at 400V (A)	Rated output (kW)	Rated operating speed (rpm)	Inverter size	Motor size
DV340-G3-0043S-TS71	3 x 320...520	1,3	0.43	1650	S	71
DV340-G3-0064S-TS80	3 x 320...520	2	0.64	1650	S	80
DV340-G3-0095S-TS80	3 x 320...520	2,8	0.95	1650	S	80
DV340-G3-0130S-TH90S	3 x 320...520	3,4	1.3	1650	S	90
DV340-G3-0190S-TH100	3 x 320...520	4,4	1.9	1650	M	100
DV340-G3-0260S-TH100	3 x 320...520	5,9	2.6	1650	M	100
DV340-G3-0380M-TH112	3 x 320...520	8,1	3.8	1650	M	112
DV340-G3-0520M-TH132	3 x 320...520	10,4	5.2	1650	M	132

RATED OPERATING SPEED G4:

Drivon	Supply voltage (ph x V)	Supply current at 400V (A)	Rated output (kW)	Rated operating speed (rpm)	Inverter size	Motor size
DV340-G4-0043S-TS71	3 x 320...520	1,2	0.43	2450	S	71
DV340-G4-0064S-TS71	3 x 320...520	1,7	0.64	2450	S	71
DV340-G4-0095S-TS80	3 x 320...520	2,3	0.95	2450	S	80
DV340-G4-0130S-TH80	3 x 320...520	2,8	1.3	2450	S	80
DV340-G4-0190M-TH90S	3 x 320...520	3,9	1.9	2450	M	90
DV340-G4-0260M-TH90L	3 x 320...520	5,4	2.6	2450	M	90
DV340-G4-0380M-TH100	3 x 320...520	7,8	3.8	2450	M	100
DV340-G4-0520M-TH100	3 x 320...520	10,6	5.2	2450	M	100

Power supply	1ph230V	3ph400V
Power range	0.25 - 1.5 kW	0.25 - 5.5 kW
Motor sizes	71-80-90	71-80-90-100-112-132
Inverter sizes	S	S-M
Constant torque speed ranges	50÷950 50÷1450	50÷950 50÷1450 50÷1650 50÷2450
Speed range	0 ÷ 3000 rpm	
Frequency range	0 ÷ 150 Hz	
Frequency resolution	0.01 Hz	
Motor control	Sensorless vectorial, V/f scalar	
Motor starting torque	200% of the rated torque	
100% torque step response	150ms	
Current overload	150% / 60s ; 200% / 3s	
Frequency reference	Integrated potentiometer, analogue input, binary fixed frequency, pulse train, fieldbus, digital Up/Down, keyboard, IP66 potentiometer, multi source (sum)	
Direction selection	Digital inputs, keyboard, fieldbus, IP66 switch (optional)	
Analogue inputs	1 x (-10÷10V) / (0-20mA)	
Digital inputs	4 multifunction (+1 optional)	
Thermal probe inputs	1 x bimetallic (+1 x PTC/PT100 optional)	
Built-in potentiometer	1 with Start/Stop function (+1 optional IP66)	
Encoder input	1 incremental Line Driver (speed loop)	
Analogue outputs	1 x (0-10V) multifunction (optional)	
Digital Outputs	1 multifunction (optional)	
Relay outputs	1 multifunction (+1 optional)	
Serial interfaces	USB	
Integrated field BUS	CANopen 402, Modbus RTU	
Optional field buses	Profibus DPV1, Ethercat, Ethernet-IP, Profinet	
Optional expansion modules	I/O expansion; EM brake control; Dynamic braking chopper; External IP66 Potentiometer and Direction Selector	
Integrated safety	Safe Torque Off, short circuit, temperature	
On-board power supplies	1x10V, 1x24VDC	
Other Functions	<ul style="list-style-type: none"> • Parametric V/f curve (V/f control mode) • Parametric S ramps • PI process controller • Jog function • Electronic torque limiter • DC-bus accessible • Integrated multiple dynamic braking • Parameter Copy Keyboard • I/O Expansions (optional) • Braking chopper and resistor (optional) • Synchronised electromechanical brake control (optional) • Configuration software via PC with integrated digital oscilloscope 	
Other options	Emergency stop button, quick Power and Signal connectors	
Protection rating	IP55-56-66	

9.2.1 Version DV123

Rated operating speed G1

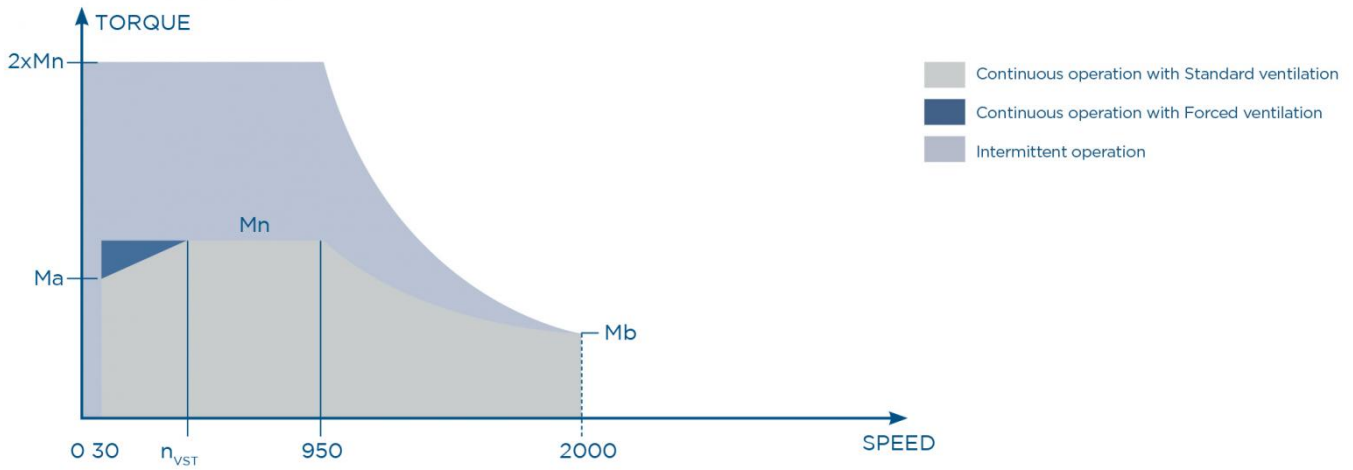

- Pn** = motor shaft nominal power
- Mn** = continuous nominal torque
- Ma** = continuous torque at minimum speed
- Mb** = continuous torque at maximum speed
- nn** = rated speed
- nmin** = minimum speed
- nmax** = maximum speed
- nVST** = forced ventilation speed threshold
- IC411** = STANDARD ventilation
- IC416** = FORCED ventilation
- (1)** With a 230V supply voltage
- (2)** At an ambient temperature of 25 °C and a carrier frequency of 8 kHz

Drivon					Pn (kW)	n _n (rpm)	Mn (Nm) (1)	n _{max} (rpm)	Mb (Nm) (1)	n _{min} (rpm)	Ma (Nm) (1)		n _{VST} (rpm) (2)
											IC411	IC416	
DV	123	G1	0025S	TS71	0,25	950	2,5	2000	1,2	30	1,1	2,5	180
DV	123	G1	0037S	TS80	0,37	950	3,7	2000	1,8	30	1,6	3,7	180
DV	123	G1	0055S	TS80	0,55	950	5,5	2000	2,6	30	2,4	5,5	180
DV	123	G1	0075S	TH90S	0,75	950	7,5	2000	3,6	30	3,3	7,5	200
DV	123	G1	0110S	TH90L	1,1	950	11,1	2000	5,3	30	4,9	11,1	200
DV	123	G1	0150S	TH100L	1,5	950	15,1	2000	7,2	30	6,6	15,1	300

Rated operating speed G2

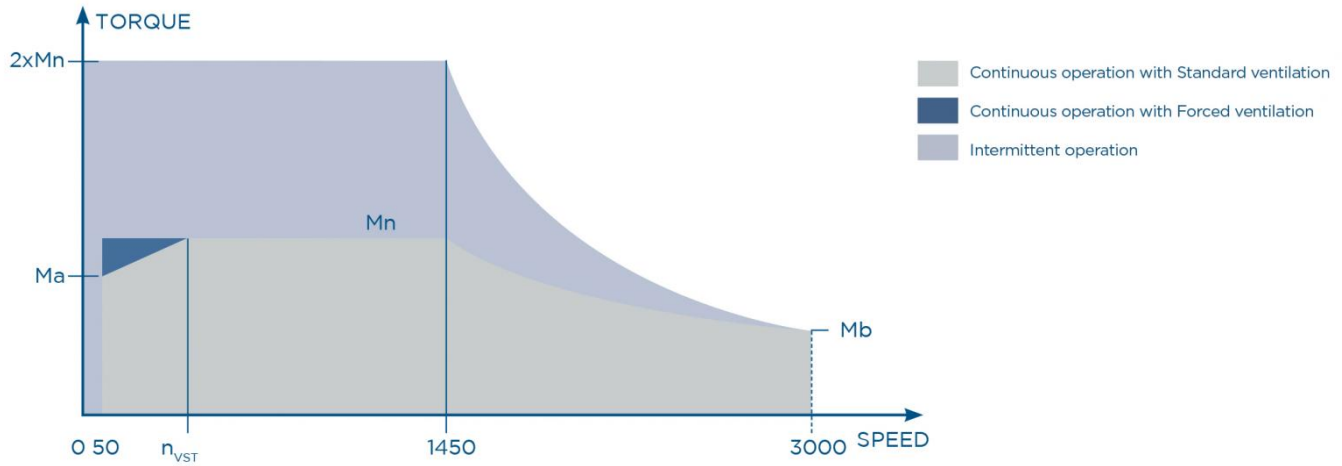

- Pn** = motor shaft nominal power
- Mn** = continuous nominal torque
- Ma** = continuous torque at minimum speed
- Mb** = continuous torque at maximum speed
- nn** = rated speed
- nmin** = minimum speed
- nmax** = maximum speed
- nVST** = forced ventilation speed threshold
- IC411** = STANDARD ventilation
- IC416** = FORCED ventilation
- (1)** With a 230V supply voltage
- (2)** At an ambient temperature of 25 °C and a carrier frequency of 8 kHz

Drivon					Pn (kW)	n _n (rpm)	Mn (Nm) (1)	n _{max} (rpm)	Mb (Nm) (1)	n _{min} (rpm)	Ma (Nm) (1)		n _{VST} (rpm) (2)
											IC411	IC416	
DV	123	G2	0025S	TS71	0,25	1450	1,6	3000	0,7	50	0,7	1,6	250
DV	123	G2	0037S	TS71	0,37	1450	2,4	3000	1,1	50	1,1	2,4	250
DV	123	G2	0055S	TS80	0,55	1450	3,6	3000	1,6	50	1,6	3,6	250
DV	123	G2	0075S	TH80	0,75	1450	4,9	3000	2,1	50	2,2	4,9	250
DV	123	G2	0110S	TH90S	1,1	1450	7,2	3000	3,1	50	3,2	7,2	250
DV	123	G2	0150S	TH90L	1,5	1450	9,9	3000	4,3	50	4,4	9,9	400

9.2.2 Version DV340

Rated operating speed G1

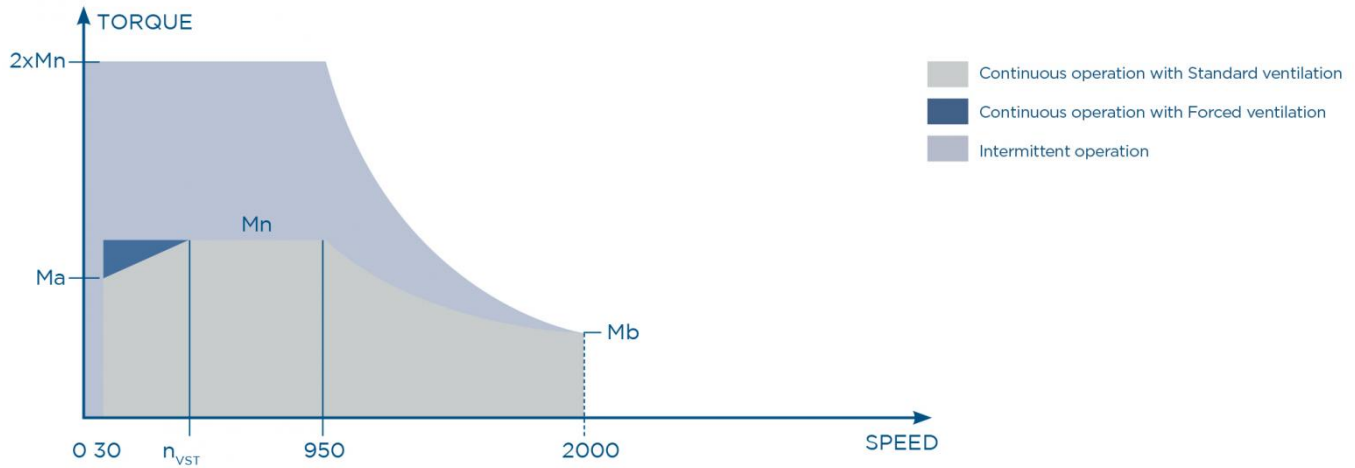

- P_n** = motor shaft nominal power
- M_n** = continuous nominal torque
- M_a** = continuous torque at minimum speed
- M_b** = continuous torque at maximum speed
- n_n** = rated speed
- n_{min}** = minimum speed
- n_{max}** = maximum speed
- n_{VST}** = forced ventilation speed threshold
- IC411** = STANDARD ventilation
- IC416** = FORCED ventilation
- (1)** With a 400V supply voltage
- (2)** At an ambient temperature of 25 °C and a carrier frequency of 8 kHz

Drivon					P _n (kW)	n _n (rpm)	M _n (Nm) (1)	n _{max} (rpm)	M _b (Nm) (1)	n _{min} (rpm)	M _a (Nm) (1)		n _{VST} (rpm) (2)
				IC411							IC416		
DV	340	G1	0025S	TS71	0,25	950	2,5	2000	1,2	30	1,1	2,5	180
DV	340	G1	0037S	TS80	0,37	950	3,7	2000	1,8	30	1,6	3,7	180
DV	340	G1	0055S	TS80	0,55	950	5,5	2000	2,6	30	2,4	5,5	180
DV	340	G1	0075S	TH90S	0,75	950	7,5	2000	3,6	30	3,3	7,5	200
DV	340	G1	0110S	TH90L	1,1	950	11,1	2000	5,3	30	4,9	11,1	200
DV	340	G1	0150S	TH100L	1,5	950	15,1	2000	7,2	30	6,6	15,1	300
DV	340	G1	0220M	TH112	2,2	950	22,1	2000	10,5	30	9,7	22,1	350
DV	340	G1	0300M	TH132	3	950	30,2	2000	14,3	30	13,3	30,2	350
DV	340	G1	0400M	TH132	4	950	40,2	2000	19,1	30	17,8	40,2	350
DV	340	G1	0550M	TH132	5,5	950	55,5	2000	26,3	30	24,4	55,5	400

Rated operating speed G2

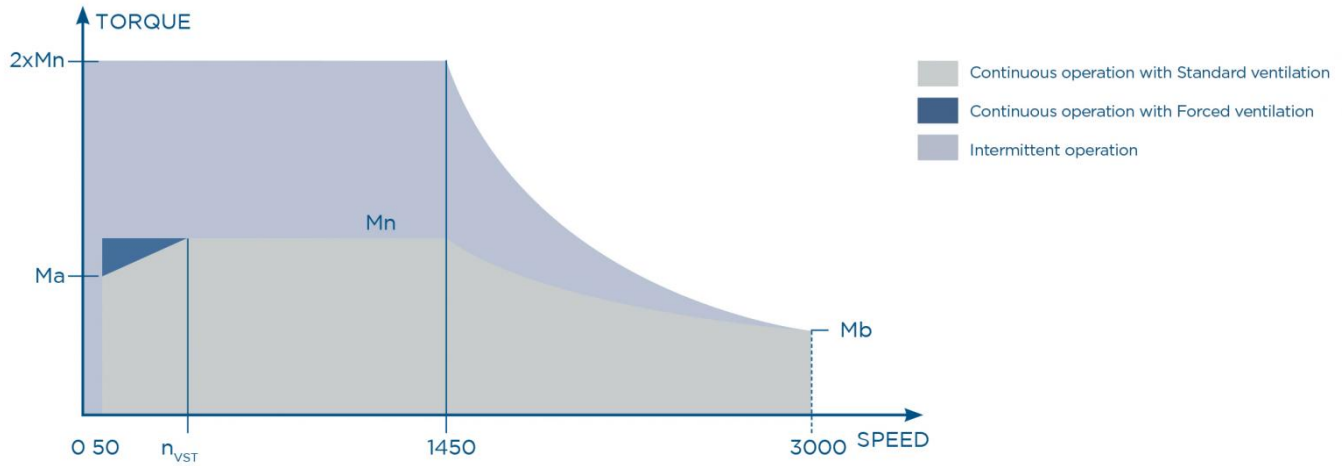

- Pn** = motor shaft nominal power
- Mn** = continuous nominal torque
- Ma** = continuous torque at minimum speed
- Mb** = continuous torque at maximum speed
- nn** = rated speed
- nmin** = minimum speed
- nmax** = maximum speed
- nVST** = forced ventilation speed threshold
- IC411** = STANDARD ventilation
- IC416** = FORCED ventilation
- (1)** With a 400V supply voltage
- (2)** At an ambient temperature of 25 °C and a carrier frequency of 8 kHz

Drivon					Pn (kW)	n _n (rpm)	Mn (Nm) (1)	n _{max} (rpm)	Mb (Nm) (1)	n _{min} (rpm)	Ma (Nm) (1)		n _{VST} (rpm) (2)
											IC411	IC416	
DV	340	G2	0025S	TS71	0,25	1450	1,6	3000	0,7	50	0,7	1,6	250
DV	340	G2	0037S	TS71	0,37	1450	2,4	3000	1,1	50	1,1	2,4	250
DV	340	G2	0055S	TS80	0,55	1450	3,6	3000	1,6	50	1,6	3,6	250
DV	340	G2	0075S	TH80	0,75	1450	4,9	3000	2,1	50	2,2	4,9	250
DV	340	G2	0110S	TH90S	1,1	1450	7,2	3000	3,1	50	3,2	7,2	250
DV	340	G2	0150S	TH90L	1,5	1450	9,9	3000	4,3	50	4,4	9,9	400
DV	340	G2	0220M	TH100	2,2	1450	14,5	3000	6,3	50	6,5	14,5	500
DV	340	G2	0300M	TH100	3	1450	19,8	3000	8,6	50	8,9	19,8	500
DV	340	G2	0400M	TH112	4	1450	26,4	3000	11,4	50	11,8	26,4	500
DV	340	G2	0550M	TH132	5,5	1450	36,2	3000	15,7	50	16,2	36,2	600

Rated operating speed G3

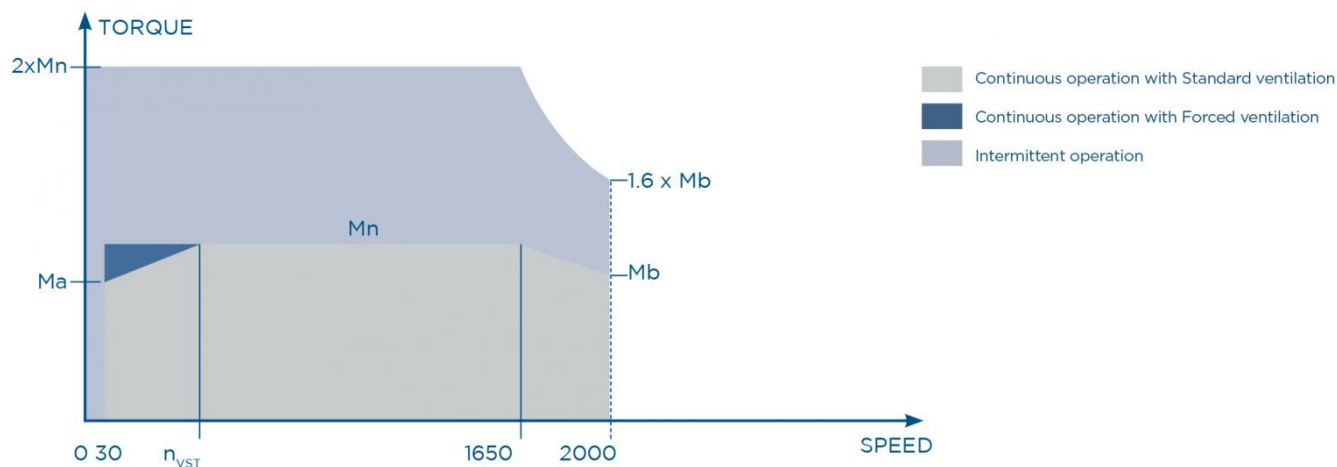

- P_n** = motor shaft nominal power
- M_n** = continuous nominal torque
- M_a** = continuous torque at minimum speed
- M_b** = continuous torque at maximum speed
- n_n** = rated speed
- n_{min}** = minimum speed
- n_{max}** = maximum speed
- n_{VST}** = forced ventilation speed threshold
- IC411** = STANDARD ventilation
- IC416** = FORCED ventilation
- (1)** With a 400V supply voltage
- (2)** At an ambient temperature of 25 °C and a carrier frequency of 8 kHz

Drivon					P _n (kW)	n _n (rpm)	M _n (Nm) (1)	n _{max} (rpm)	M _b (Nm) (1)	n _{min} (rpm)	M _a (Nm) (1)		n _{VST} (rpm) (2)
				IC411							IC416		
DV	340	G3	0043S	TS71	0,43	1650	2,5	2000	1,2	30	1,1	2,5	180
DV	340	G3	0064S	TS80	0,64	1650	3,7	2000	1,8	30	1,6	3,7	180
DV	340	G3	0095S	TS80	0,95	1650	5,5	2000	2,6	30	2,4	5,5	180
DV	340	G3	0130S	TH90S	1,3	1650	7,5	2000	3,6	30	3,3	7,5	200
DV	340	G3	0190M	TH90L	1,9	1650	11,1	2000	5,3	30	4,9	11,1	200
DV	340	G3	0260M	TH100L	2,6	1650	15,1	2000	7,2	30	6,6	15,1	300
DV	340	G3	0380M	TH112	3,8	1650	22,1	2000	10,5	30	9,7	22,1	350
DV	340	G3	0520M	TH132	5,2	1650	30,2	2000	14,3	30	13,3	30,2	350

Rated operating speed G4

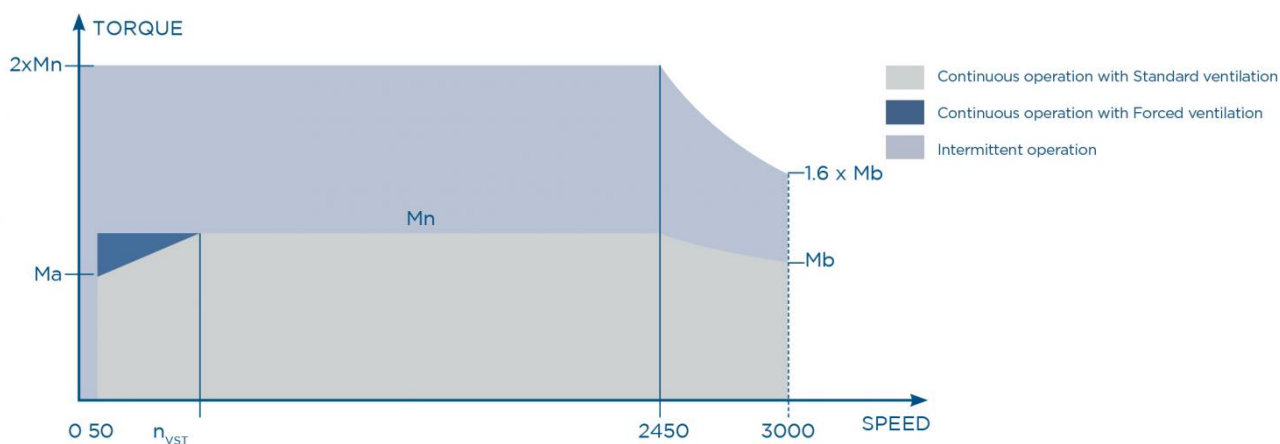

- P_n** = motor shaft nominal power
- M_n** = continuous nominal torque
- M_a** = continuous torque at minimum speed
- M_b** = continuous torque at maximum speed
- n_n** = rated speed
- n_{min}** = minimum speed
- n_{max}** = maximum speed
- n_{VST}** = forced ventilation speed threshold
- IC411** = STANDARD ventilation
- IC416** = FORCED ventilation
- (1)** With a 400V supply voltage
- (2)** At an ambient temperature of 25 °C and a carrier frequency of 8 kHz

Drivon					P _n (kW)	n _n (rpm)	M _n (Nm) (1)	n _{max} (rpm)	M _b (Nm) (1)	n _{min} (rpm)	M _a (Nm) (1)		n _{VST} (rpm) (2)
											IC411	IC416	
DV	340	G4	0043S	TS71	0,43	2450	1,6	3000	0,7	50	0,7	1,6	250
DV	340	G4	0064S	TS71	0,64	2450	2,4	3000	1,1	50	1,1	2,4	250
DV	340	G4	0095S	TS80	0,95	2450	3,6	3000	1,7	50	1,6	3,6	250
DV	340	G4	0130S	TH80	1,3	2450	4,9	3000	2,3	50	2,2	4,9	250
DV	340	G4	0190M	TH90S	1,9	2450	7,2	3000	3,4	50	3,2	7,2	250
DV	340	G4	0260M	TH90L	2,6	2450	9,9	3000	4,7	50	4,4	9,9	400
DV	340	G4	0380M	TH100	3,8	2450	14,5	3000	7	50	6,5	14,5	500
DV	340	G4	0520M	TH100	5,2	2450	19,8	3000	9,6	50	8,9	19,8	500

9.3 DIMENSIONS

9.3.1 Mounting positions B5

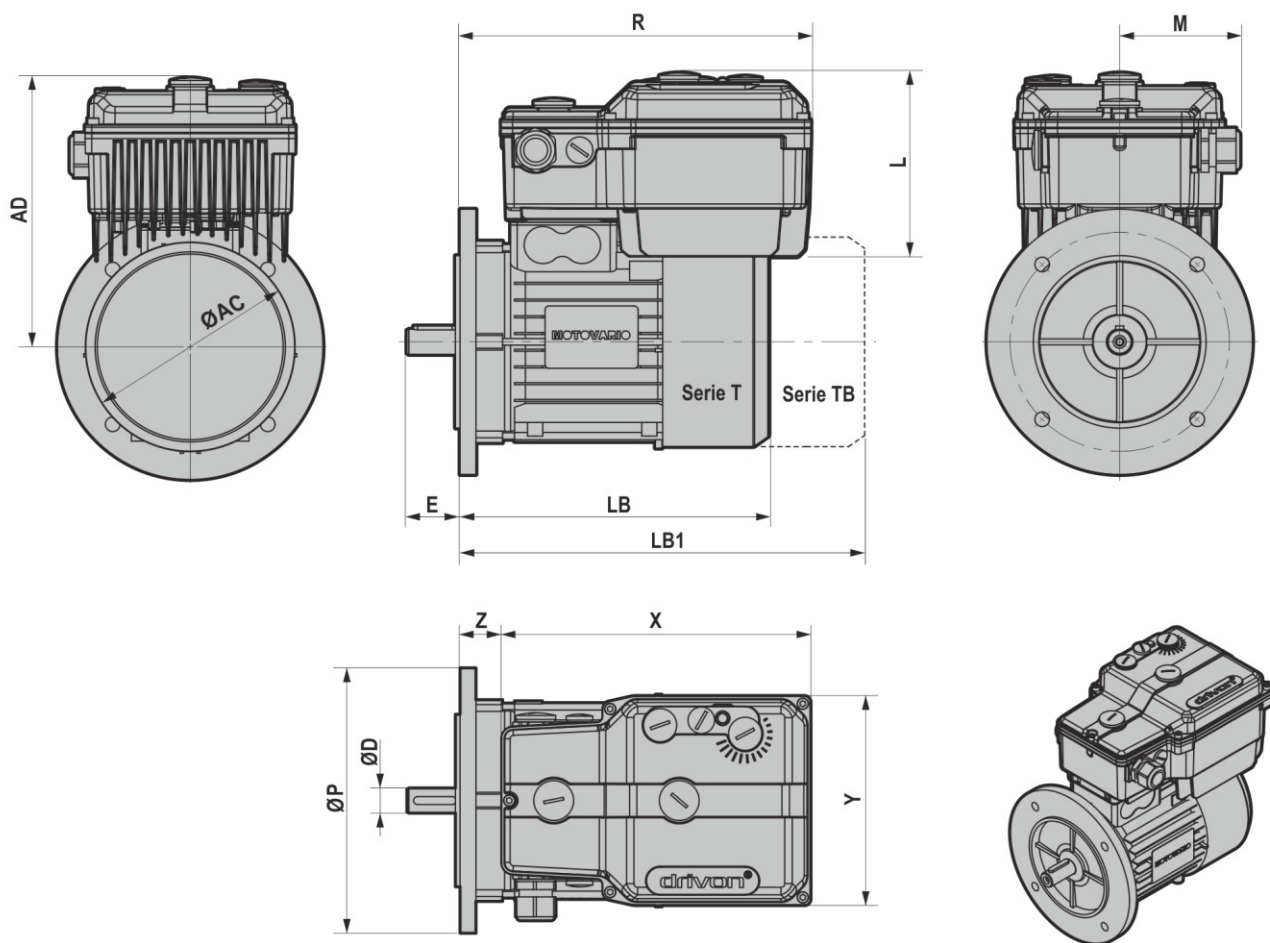

Inverter	Mot.	X	Y	L	M	Z	R	AC	P	D	E	LB	LB1	AD
S	71	233	158	139	91	27	260	139	160	14 j6	30	209	276	200
S	80	233	158	139	91	31	264	158	200	19 j6	40	233	304	209
S	90S	233	158	139	91	42	275	173	200	24 j6	50	248	325	221
S	90L	233	158	139	91	42	275	173	200	24 j6	50	273	350	221
S	100	233	158	139	91	50	283	191	250	28 j6	60	308	390	232
M	90S	258	193	152	102	33	291	173	200	24 j6	50	248	304	215
M	90L	258	193	152	102	33	291	173	200	24 j6	50	273	350	215
M	100	258	193	152	102	41	299	191	250	28 j6	60	308	390	224
M	112	258	193	152	102	44	302	211	250	28 j6	60	323	419	238
M	132S	258	193	152	102	58	316	249	300	38 k6	80	372	462	276
M	132M	258	193	152	102	58	316	249	300	38 k6	80	410	514	276

9.3 DIMENSIONS

9.3.2 Mounting positions B14

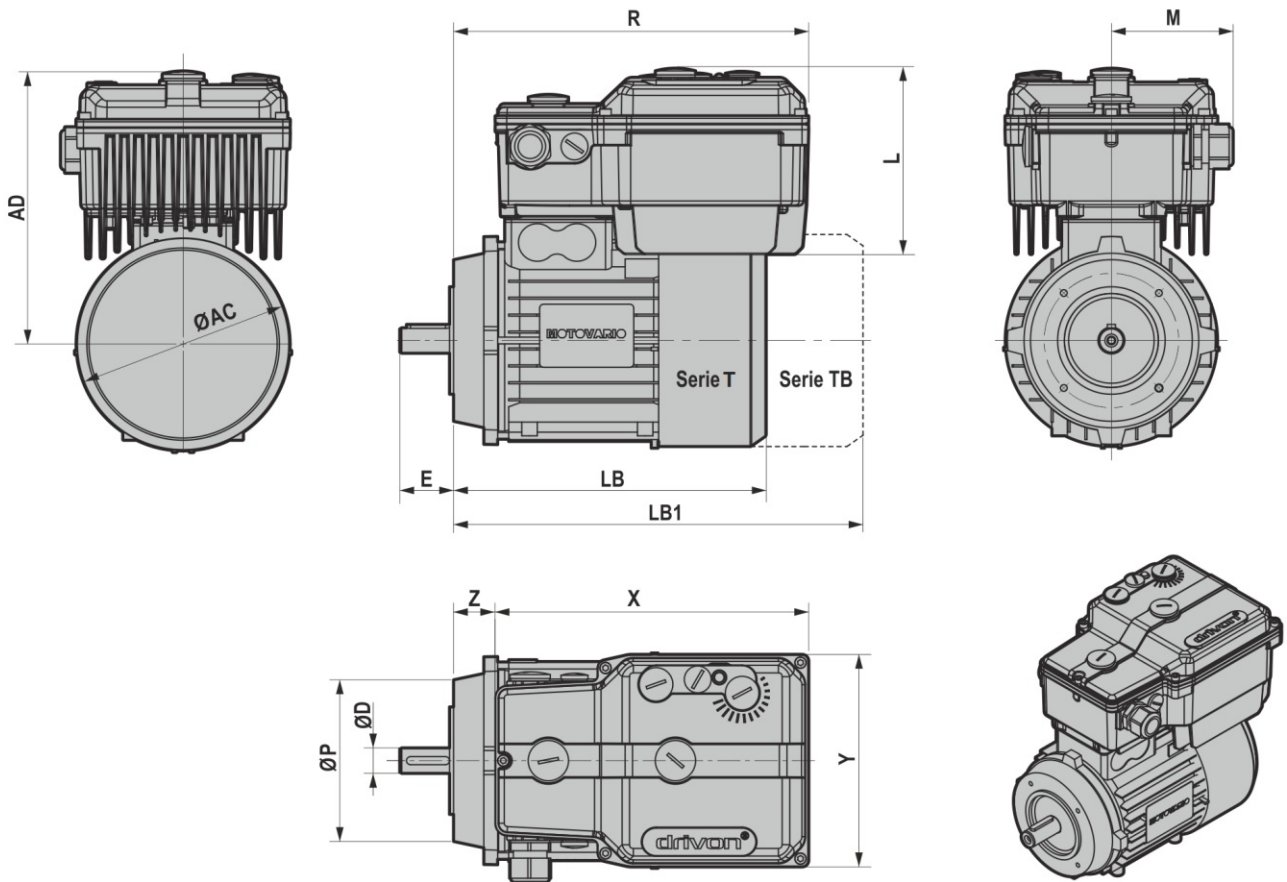

Inverter	Mot.	X	Y	L	M	Z	R	AC	P	D	E	LB	LB1	AD
S	71	233	158	139	91	27	260	139	105	14 j6	30	209	276	200
S	80	233	158	139	91	31	264	158	120	19 j6	40	233	304	209
S	90S	233	158	139	91	42	275	173	140	24 j6	50	248	325	221
S	90L	233	158	139	91	42	275	173	140	24 j6	50	273	350	221
S	100	233	158	139	91	50	283	191	160	28 j6	60	308	390	232
M	90S	258	193	152	102	42	275	173	140	24 j6	50	248	304	215
M	90L	258	193	152	102	42	275	173	140	24 j6	50	273	350	215
M	100	258	193	152	102	41	299	191	160	28 j6	60	308	390	224
M	112	258	193	152	102	44	302	211	160	28 j6	60	323	419	238
M	132S	258	193	152	102	58	316	249	200	38 k6	80	372	462	276
M	132M	258	193	152	102	58	316	249	200	38 k6	80	410	514	276

9.3 DIMENSIONS

9.3.3 Mounting positions B3

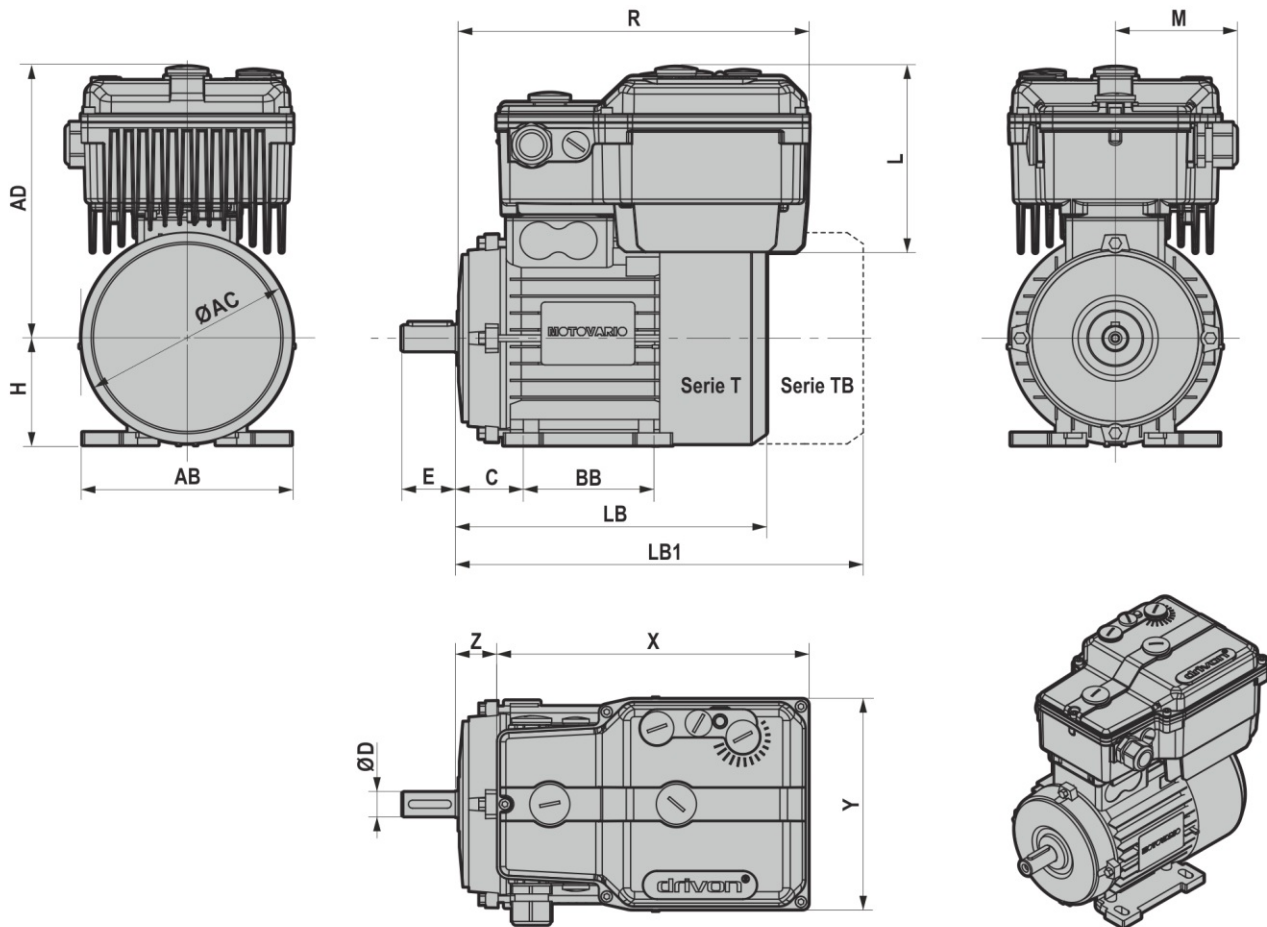

Inverter	Mot.	X	Y	L	M	Z	R	AC	D	E	LB	LB1	AD	AB	C	BB	H
S	71	233	158	139	91	27	260	139	14 j6	30	209	276	200	132	44	90	71
S	80	233	158	139	91	31	264	158	19 j6	40	233	304	209	156	49	100	80
S	90S	233	158	139	91	42	275	173	24 j6	50	248	325	221	172	54	100	90
S	90L	233	158	139	91	42	275	173	24 j6	50	273	350	221	172	54	125	90
S	100	233	158	139	91	50	283	191	28 j6	60	308	390	232	192	62	140	100
M	90S	258	193	152	102	33	291	173	24 j6	50	248	304	215	172	54	100	90
M	90L	258	193	152	102	33	291	173	24 j6	50	273	350	215	172	54	125	90
M	100	258	193	152	102	41	299	191	28 j6	60	308	390	224	192	62	140	100
M	112	258	193	152	102	44	302	211	28 j6	60	323	419	238	221	69	140	112
M	132S	258	193	152	102	58	316	249	38 k6	80	372	462	276	260	87	140	132
M	132M	258	193	152	102	58	316	249	38 k6	80	410	514	276	260	87	140	132

9.4 WEIGHTS

DV123		
Mot.	P [kW]	kg
TS71	0,37	8,18
TS80	0,55	10,58
TH80	0,75	13,86
TH90	1,1	17,36
TH90	1,5	18,56

DV340		
Mot.	P [kW]	kg
TS71	0,37	8,3
TS80	0,55	10,7
TH80	0,75	14,04
TH90	1,1	17,54
TH90	1,5	18,74
TH100	2,2	27,37
TH100	3	29,37
TH112	4	35,35
TH132	5,5	50,35

Drivon has been designed based on a modular approach so that its standard features can be expanded through appropriate hardware expansions which can be selected upon ordering. All optional accessories, with the exception of the Intelligent Keypad (KP), must be selected when ordering.

Smart keypad (option KP)



The optional keypad KP provides a control and monitoring interface for user to

- Start the inverter motor in both operating directions with two specific buttons.
- Set the inverter motor parameters by using the menus, easily available thanks to the keypad.
- Copy up to 4 different configuration sets and duplicate them infinitely on Drivon motor-inverters requiring the same operating parameters
- Monitoring motor-inverter state and diagnose its operation
- Operate the motor in JOG mode

The keypad can be used in one of the following modes:

1. Temporary remote connection

User quickly connects the keypad to the inverter through the suitable RJ connector accessible on the cover (IP20 degree of protection).

2. Permanent remote connection



User connects the keypad to the inverter through a cable gland (IP55 degree of protection). The keypad is not mechanically fixed to the inverter.

3. Permanent integrated connection



User connects the keypad electrically and mechanically to the inverter (IP66 degree of protection).

I/O expansion module (options IOA, IOB)

The I/O expansion module provides additional digital and analogue interfaces to supplement standard motor-inverter interfaces. These expansions make the following connections available:

- PT100/NTC/PTC temperature sensor input
- No.1 Auxiliary analogue input +/-10V or 4-20mA
- No.1 Digital input with frequency up to 100KHz at 24V
- No.1 24V auxiliary digital output
- No.1 Switching relay digital output (max 250V)
- No.1 0-10V analogue output with 500Hz maximum band

The same module comes in two versions - IOA and IOB - with different electric connections to the outside environment:

- IOA: version with cable gland
- IOB: version with two M12 A-code connectors (male connector for Input signals, female connector for Output signals)

Potentiometer and mode selector (option PS)

This supplementary module provides the user with an external Potentiometer and an external Direction Selector (IP66 degree of protection) for manual start and speed selection control.

- Single-turn rotary potentiometer for frequency selection 0....fmax (Hz)
- Three-position direction selector FWD/STOP/REV

Minimum and maximum frequencies, as well as acceleration and deceleration ramps are factory presets. User may make changes to these presets from the KP keypad or via the USB connection to the PC using the Motovario BSi software tool.

Electro-mechanical braking module (option EMB)

The electro-mechanical braking module implements the Operation and Control feature for a self-braking motor equipped with DC brake. This module independently activates and deactivates the brake in perfect sync with motor behaviour through flexible (user-selectable) parameter setting for response timing and speeds. It is available for all Drivon power supply options (1ph230V and 3ph400V). The inverter independently provides the brake coil with the appropriate power supply. User need not carry out any assembly or wiring connections as they are done at the factory.

This option must be requested upon ordering.

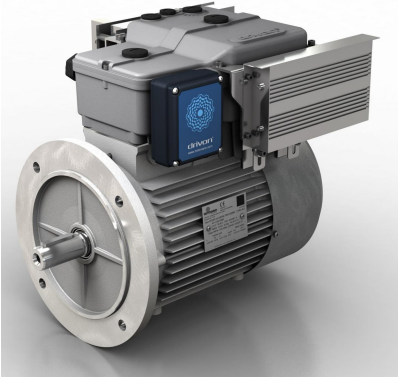
Dynamic braking module (chopper) (option BC)

Drivon has a four-segment operating principle. This means it can control the motor even when it is acting as a generator under braking and, generally speaking, when mechanical loading causes the motor to run faster than command speed. Option BC dissipates regenerated energy from the motor to an additional resistor enabling Drivon to brake the load with a power equal to nominal motor power. It consists of a resistive element and an electronic control element, both fixed to the side of the inverter. On self-braking motors, the BC module doubles as EMB module.

Profibus communication module DPV1 (option PDP)

This optional module enables the communication through standard Profibus DPV1 field bus. This module makes it possible to assign a network address through on-board manual rotary selector switches. In addition, the user can activate a termination resistor through jumpers as required. Two M12 B-code connectors (a male and female connector) are provided on the outside of the module for Line connection to field network.

Ethercat communication module (option ETC)

This optional module implements hardware and software interfaces for Real-Time-Ethernet networks over Ethercat profile. Two M12 D-code connectors (a male and a female connector) are provided on the outside of the module for Line connection to field network.

Emergency stop button (option FEM)

This option consists in an external emergency stop button that activates the Drivon's STO function.

Pressing the button cuts power to the motor in full safety in accordance with EN ISO 13849-1 and EN61508, whereas the inverter remains powered.

ATTENTION!

The revised data and information, shown in this technical catalogue, replaces the data of the previous editions. Old data is now obsolete. All technical data, dimensions, weights in this catalogue are subject to changes without warning. Illustrations are not binding. You can find the above mentioned data and information on our site www.motovario.com; please periodically consult the technical documentation on the web site to be always updated about possible modifications of performances and characteristics of the product.

All supplies effected by MOTOVARIO are governed exclusively by the general terms of sale that you can find on our website:

<http://www.motovario.com/eng/corporate/sales-conditions>

ATTENTION: Supply information

This catalogue refers to the DRIVON inverter motor, comprising an electric motor and an inverter, both supplied by Motovario. The combination of the single inverter to any electric motor manufactured by other companies does not guarantee the performance values indicated in this catalogue and consequently it does not fall under the Warranty Conditions of Motovario S.p.A.

